

Professor T. C. Hu ISPD-2018 Lifetime Achievement Commemoration

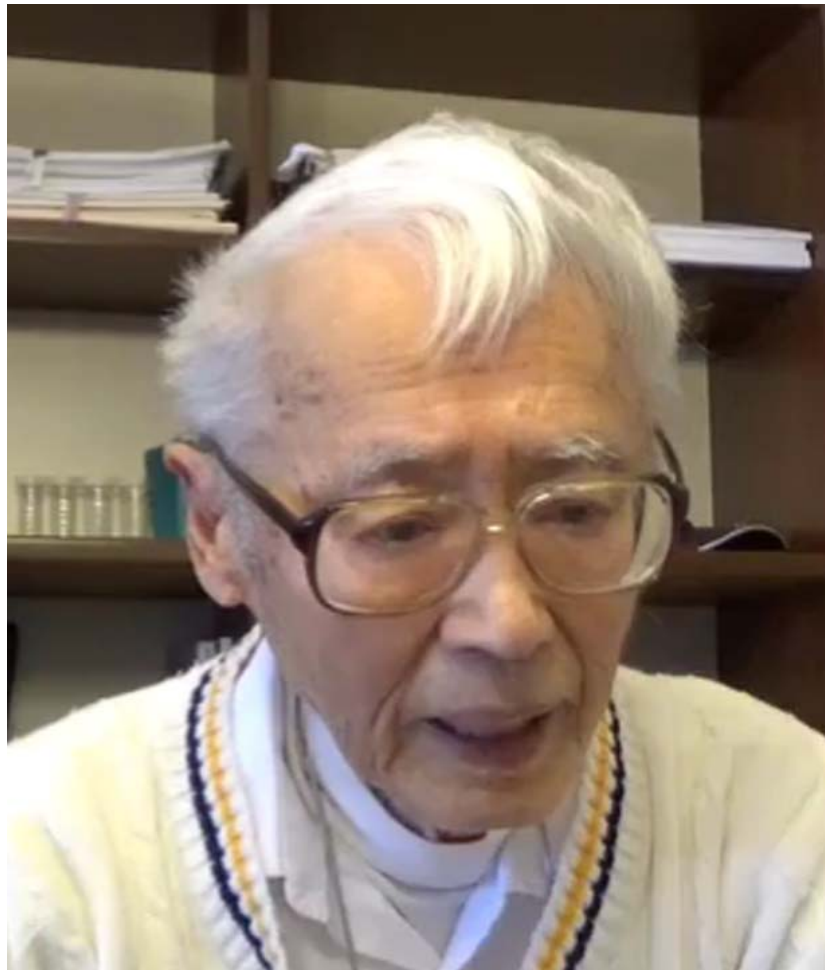

Influence of Professor T. C. Hu's Works on Fundamental Approaches in Layout

**Andrew B. Kahng
CSE and ECE Departments
UC San Diego**

<http://vlsicad.ucsd.edu>

Professor T. C. Hu

- **Introduced combinatorial optimization, and mathematical programming formulations and methods, to VLSI Layout**
- **Many works reflect unique ability to combine geometric, graph-theoretic, and combinatorial-algorithmic ideas**
 - **1961: Gomory-Hu cut tree**
 - **1973: Adolphson-Hu cut-based linear placement**
 - **1985: Hu-Moerder hyperedge net model**
 - **1985: Hu-Shing α - β routing**
- **Applications of duality: flows and cuts, shadow price → Professor C.-K. Cheng in next talk**

Professor T. C. Hu

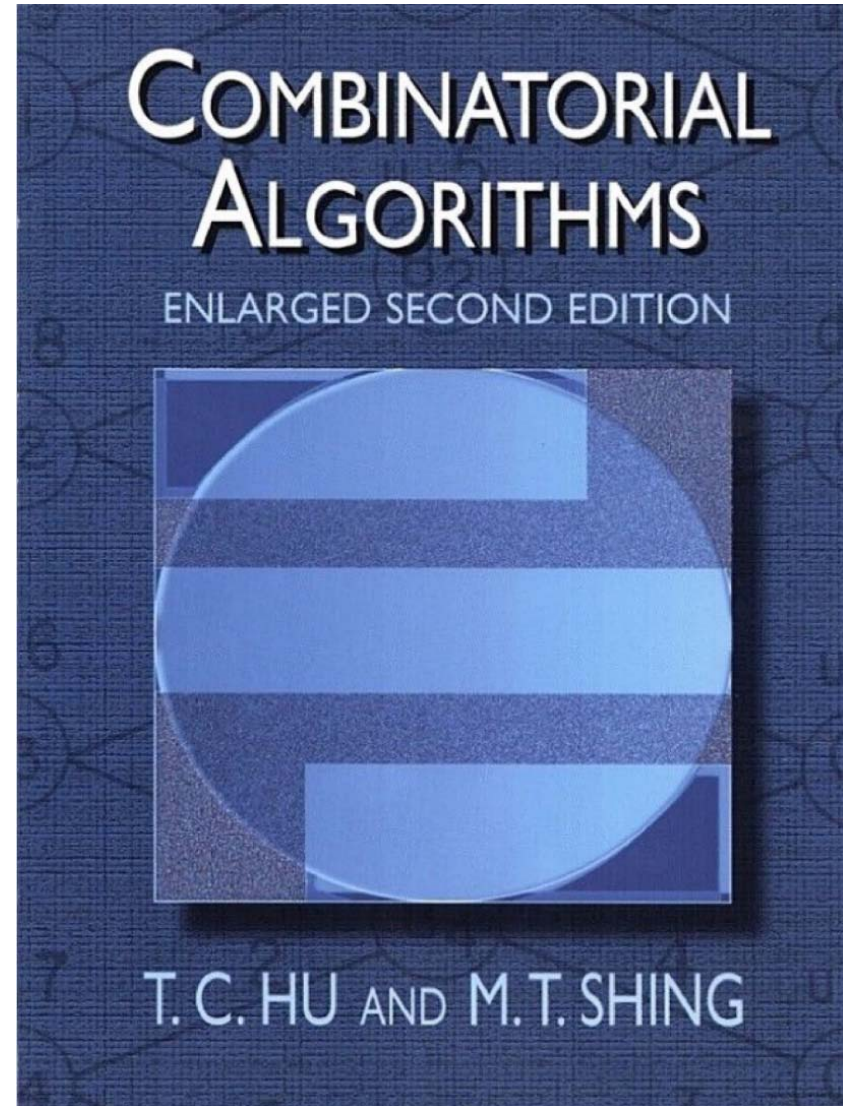
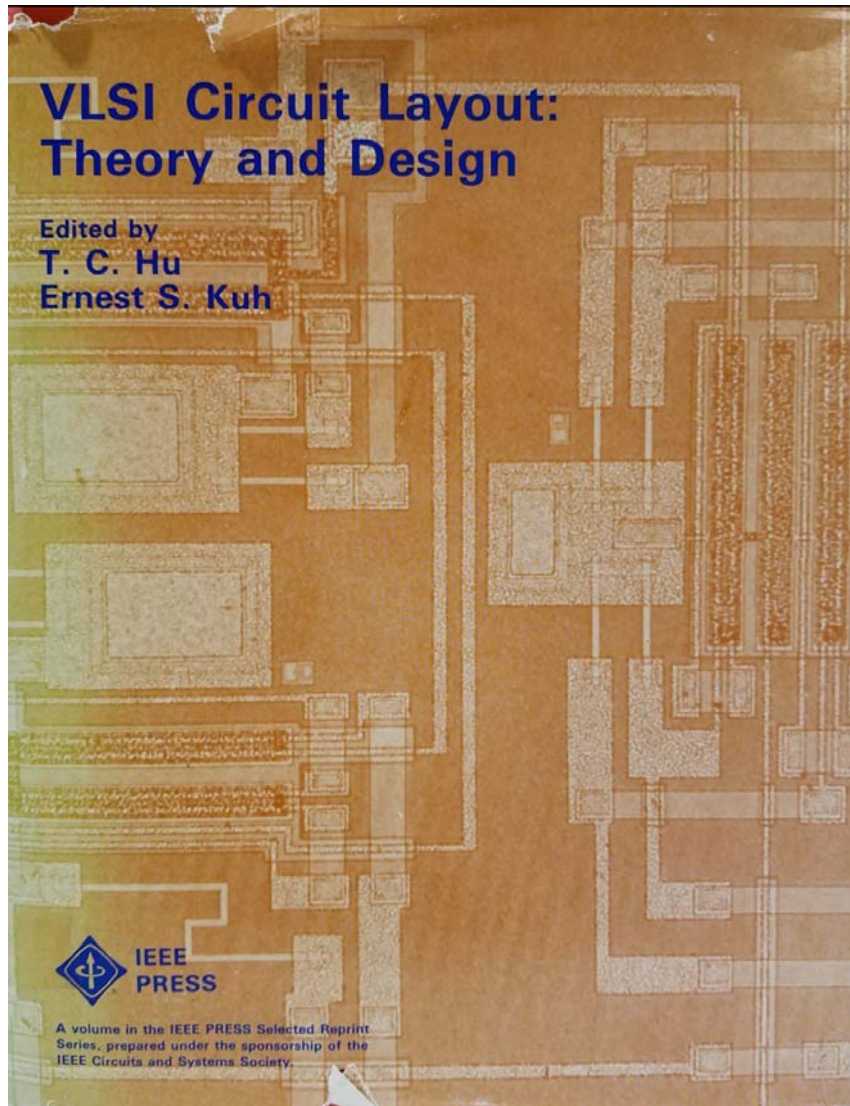

A Few Examples

- **Tentative Assignment / Competitive Pricing**
- **Optimal Linear Ordering**
- **Hyperedge Net Model**
- **The Prim-Dijkstra Tradeoff**
- **The Discrete Plateau Problem and Finding a Wide Path**

A Few Examples

- **Tentative Assignment / Competitive Pricing**
- **Optimal Linear Ordering**
- **Hyperedge Net Model**
- **The Prim-Dijkstra Tradeoff**
- **The Discrete Plateau Problem and Finding a Wide Path**

TACP and Shadow Price (1)

- TACP: tentative assignment and competitive pricing
- Application: Fixed-outline floorplanning
 - Fixed die, fixed block aspect ratio
 - \neq classical “packing” that minimizes whitespace, etc. !!!
 - Seeks “perfect” rectilinear floorplanning: zero whitespace
 - Irregular block shape
 - Overlapping blocks

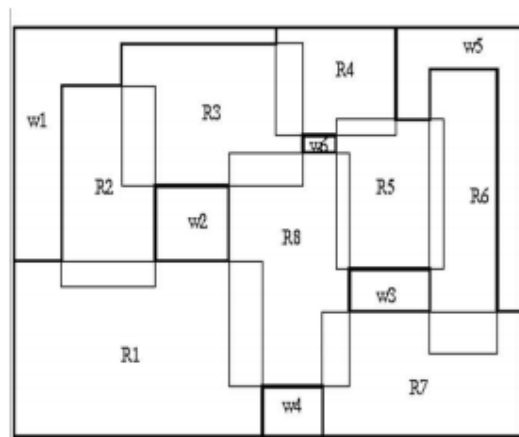

(a)

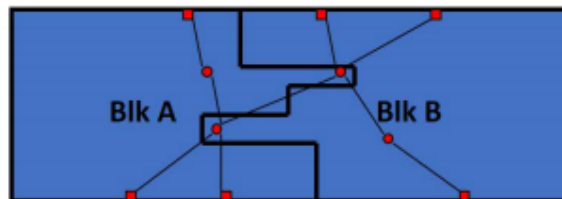

(b)

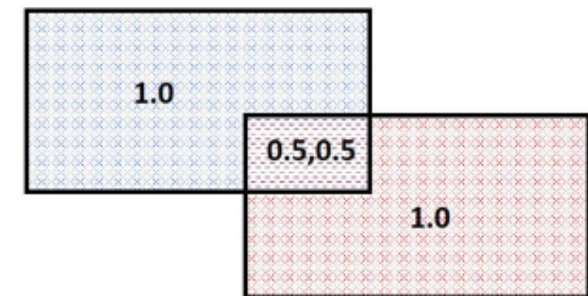

(c)

TACP and Shadow Price (2)

- Shadow price in linear programming duality
 - Primal-dual iterations in global routing
 - Local density in global placement
 - Global density

$$\min f(\mathbf{v}) = W(\mathbf{v}) + \lambda \cdot D(\mathbf{v})$$

- More recent: constraint-oriented local density

$$\min f(\mathbf{v}) = W(\mathbf{v}) + \sum_i \lambda_i \cdot D_i(\mathbf{v})$$

Better cell spreading, better wirelength!

A Few Examples

- **Tentative Assignment / Competitive Pricing**
- **Optimal Linear Ordering**
- **Hyperedge Net Model**
- **The Prim-Dijkstra Tradeoff**
- **The Discrete Plateau Problem and Finding a Wide Path**

Linear Placement

- Optimal linear ordering (O.L.O.) problem
 - n pins in n holes, 1 pin per hole
 - Holes in a line, unit distance apart
 - Minimize the wirelength
- Gomory and Hu / Adolphson and Hu
 - $n(n - 1)/2$ max flow values between any source / sink nodes can be obtained with $(n - 1)$ max flow problems, giving $(n - 1)$ fundamental cuts
 - $(n - 1)$ fundamental cuts are lower bound for O.L.O.

The min-cut defines an ordered partition that is consistent with an optimal vertex order in the linear placement problem.

Minimum Cuts in Placement

- Recursive min-cut
 - [Cheng87]: universal application to VLSI placement
 - Capo: top-down, min-cut bisection
 - Feng Shui: general purpose mixed-size placer
- Duality between max flows and min cuts
 - [Yang96]: flow-based balanced netlist bipartition
 - MLPart: multilevel KL-FM/ flat KL-FM / flow-based partitioning

Linear Placements Today

- Single-row placement
 - Variable cell width
 - Fixed row length with free sites
 - Fixed cell ordering

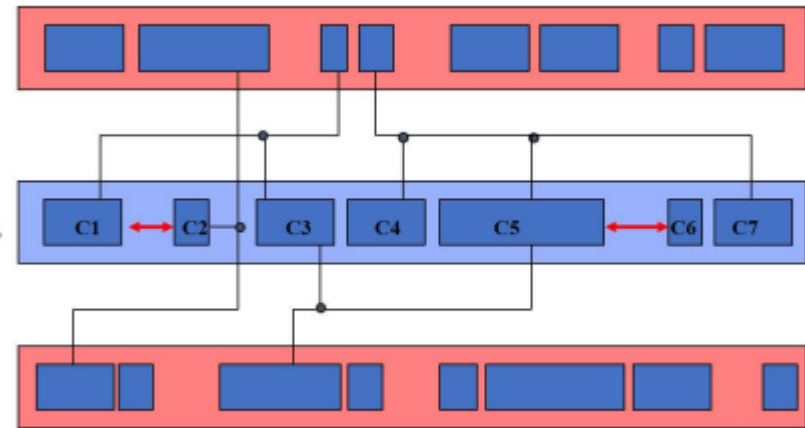

- Multi-row placement
 - Local layout effect-aware
 - Reorderable cells
 - Support of multi-height cells

Different horizontal fin-to-fin spacing $d \neq d'$
 Two fins in T2 have different drive strength

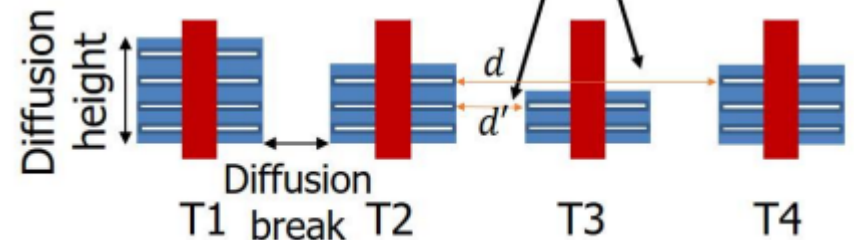

- Diffusion
- Fin
- ▭ Diffusion Cut
- PC
- Cell

A Few Examples

- **Tentative Assignment / Competitive Pricing**
- **Optimal Linear Ordering**
- **Hyperedge Net Model**
- **The Prim-Dijkstra Tradeoff**
- **The Discrete Plateau Problem and Finding a Wide Path**

Net Modeling

- “Multiterminal Flows in a Hypergraph”, Hu and Moerder, 1985
- Challenging question:
 - How should a hyperedge of a hypergraph be modeled by graph edges in a graph model of the hypergraph?
 - Applications for analytic placement, for exploiting sparse-matrix codes for layouts

- **New hyperedge net model - p pin nodes and one star node to represent a p -pin hyperedge**

Example Transformation

- Transform netlist hypergraph
 - Add one star node for each signal net
 - Connect star node to each pin node (via a graph edge)
 - Sparse, symmetric + exactly captures true cut cost
- Star model: [Brenner01], BonnPlace [Brenner08]

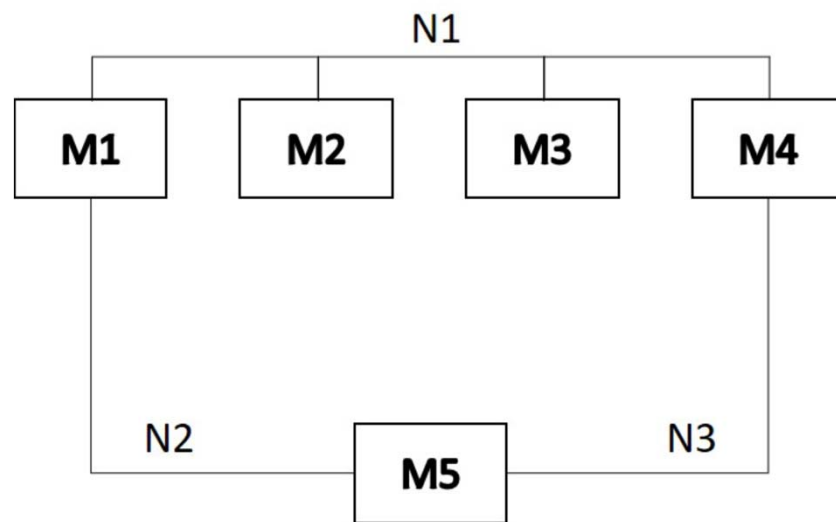

Example circuit with 5 modules
and 3 nets

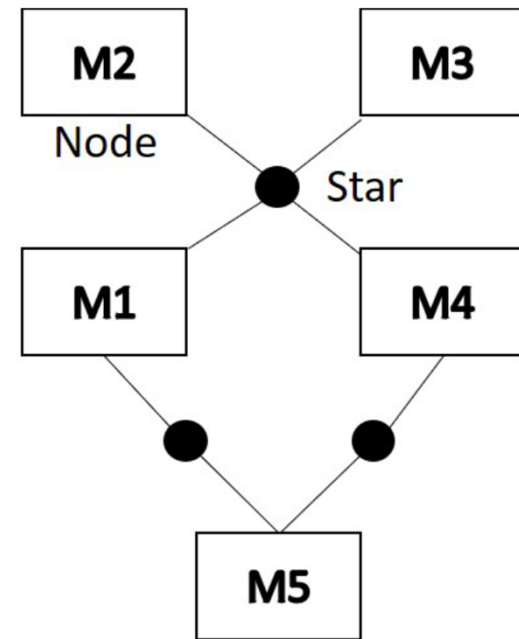

Equivalent hypergraph model

A Few Examples

- **Tentative Assignment / Competitive Pricing**
- **Optimal Linear Ordering**
- **Hyperedge Net Model**
- **The Prim-Dijkstra Tradeoff**
- **The Discrete Plateau Problem and Finding a Wide Path**

The Prim-Dijkstra Tradeoff

- **Prim's Minimum Spanning Tree (MST)**
 - Iteratively add edge e_{ij} to T , such that $v_i \in T$, $v_j \notin T$ and d_{ij} is minimum
 - **Minimizes tree wirelength (WL)**
- **Dijkstra's Shortest Path Tree (SPT)**
 - Iteratively add edge e_{ij} to T , such that $v_i \in T$, $v_j \notin T$ and $l_i + d_{ij}$ is minimum (where l_i is source-to-sink pathlength of v_i)
 - **Minimizes source-to-sink pathlengths (PLs)**
- **Prim-Dijkstra Tradeoff (Alpert, Hu, Huang, Kahng, 1993)**
 - **"PD1" tradeoff: iteratively add e_{ij} to T that minimizes $c \cdot l_i + d_{ij}$**
 - $c = 0 \rightarrow$ Prim's MST
 - $c = 1 \rightarrow$ Dijkstra's SPT // c enables balancing of tree WL, source-sink PLs
 - **"PD2" tradeoff: iteratively add e_{ij} to T that minimizes $(l_i^p + d_{ij})^{1/p}$**
 - $p = \infty \rightarrow$ Prim's MST;
 - $p = 1 \rightarrow$ Dijkstra's SPT

Prim-Dijkstra Construction

Prim's Minimum Spanning Tree (MST)
Minimizes wirelength

But large pathlengths
to nodes 3,4,5

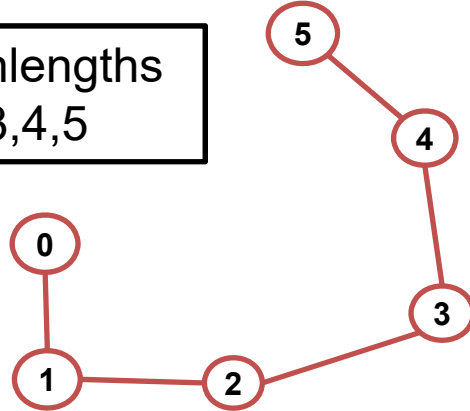

Prim-Dijkstra (PD) tradeoff

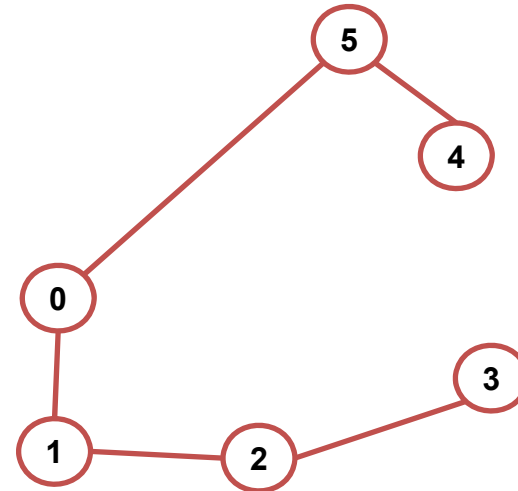

Dijkstra's Shortest Path Tree (SPT)
Minimizes source-sink pathlengths

But large tree
wirelength!

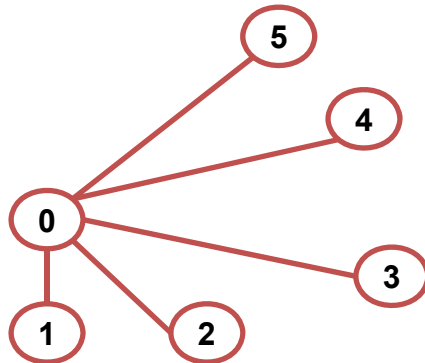

**Directly trades off the
Prim, Dijkstra constructions**

PD Tradeoff: 25 Years of Impact

- Widely used
 - In EDA for timing estimation, buffer tree construction and global routing
 - In flood control, biomedical, military, wireless sensor networks, etc.
- Simple and fast – $O(n \log n)$
- Alpert et al., DAC06: PD is practically ‘free’

- Yesterday: “PD Revisited”
 - Iterative repair of spanning tree
 - Detour-aware Steinerization
 - Better WL, PL tradeoff

A Few Examples

- **Tentative Assignment / Competitive Pricing**
- **Optimal Linear Ordering**
- **Hyperedge Net Model**
- **The Prim-Dijkstra Tradeoff**
- **The Discrete Plateau Problem and Finding a Wide Path**

Connection Finding

- Basic element of any routing approach
- α - β routing (Hu and Shing, 1985)
 - Find connections given edge and vertex costs
 - Comprehend existence of “turn” at vertex
 - Provide unified elements for
 - Dijkstra’s algorithm
 - Best-first (A^*) search

Proc. Nat. Acad. Sci., October 1992

Floating an Answer to Bubble Riddle

■ **Science:** Research team comes up with a solution to a 150-year-old brain teaser. The findings could have practical applications and lead to a new branch of math.

By NORA ZAMICHOW
TIMES STAFF WRITER

If you take a wire, bend it to create a loop, and stick it in soapy water, what shape bubbles will you create?

This question has tormented mathematicians for 150 years.

A team of three researchers has come up with a solution, one it believes may even have some practical applications for solving problems with robots and computer chip design. In fact, the scientists believe, their work may pave the way to a new

branch of mathematics: dimensional geometry.

In devising a solution, the three added thickness and weight to the equation, removing the problem from the ideal realm of mathematics and putting it into the everyday world, in which objects have dimensions.

"Just as the subject of probability started from a gambler's question and the subject of geometry started from partitioning flooded land in the Nile River valley in Egypt, so the question of minimum surfaces with thickness and weight may lead to a new branch of mathematics," said T. C. Hu,

a professor of computer science and engineering at UC San Diego.

Hu's quest for the soap bubble solution, published in today's issue of the journal *Proceedings of the National Academy of Science*, began in 1963. If you ask Hu why he has battled this problem, he'll give you a because-it-was-there answer.

"These kinds of questions *should* be answered," Hu said. "The Plateau problem was dealing with the ideal, but everything has thickness and weight. So we solved *that* kind of problem."

Other mathematicians applauded Hu's efforts, saying the findings will help solve similar as well as more complicated problems down the road.

"This is quite significant. It provides a practical solution of a fundamental problem that's typical of many other problems," said

Please see BUBBLE, B2



UC San Diego

UCSD Prof. T. C. Hu

- Discrete version of Plateau's minimum-surface problem
- Solved using duality of cuts and flow



Bubble puzzle: Plateau Problem researchers are (from left) Gabriel Robins, Andrew Kahng and T.C. Hu.

Scientists float a new solution to puzzling bubble

By SCOTT LALEE, Staff Writer

A UCSD scientist and two colleagues have added weight to a 150-year-old question involving soap bubbles, a contribution that may ultimately lead to better robots and a new branch of mathematics.

Reporting in today's issue of the *Proceedings of the National Academy of Sciences*, the team describes a method of mathematically defining not just the surface dimensions of a soap bubble within a wire ring, but also the bubble's surface weight and thickness.

"We think there's a lot of power in the idea," said Andrew Kahng of the University of California Los Angeles.

T.C. Hu, a professor of computer science at the

See Bubble on Page B-8

Towards Robust (Wide) Path Finding

- Robust path finding problem
 - Source-destination routing with prescribed width
 - Seek minimum-cost path that has robustness (width) = d
 - E.g., a mobile agent with finite width

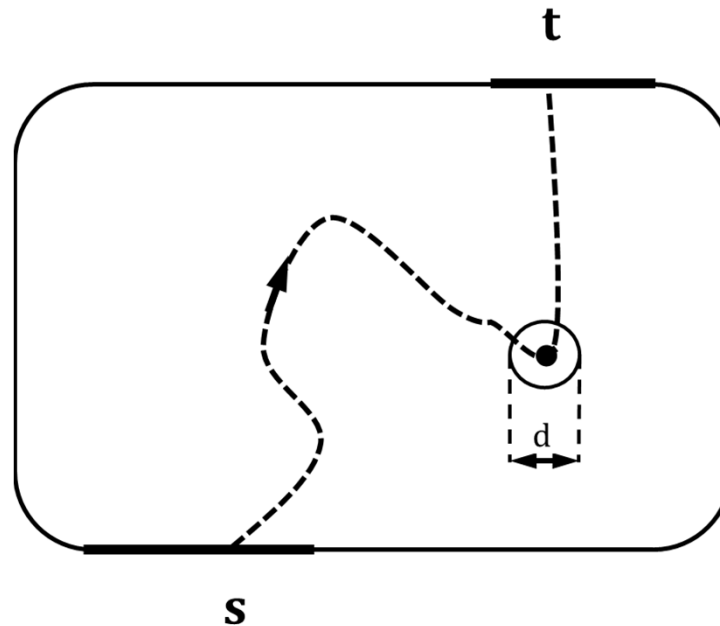

Network Flow Approach

- Discretize routing environment
- A minimum cut in flow network
 - Contain all vertices and edges on a robust path
 - Correspond to a maximum flow by duality
 - Return a robust path

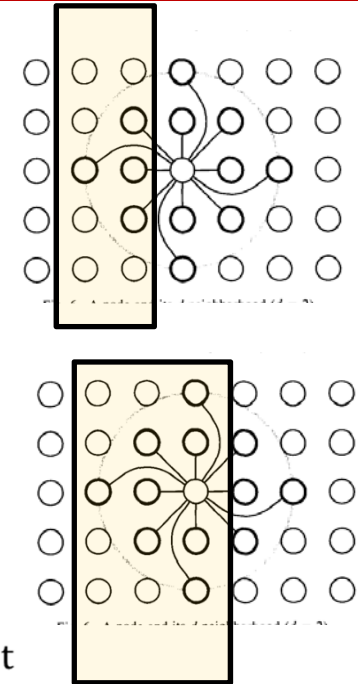
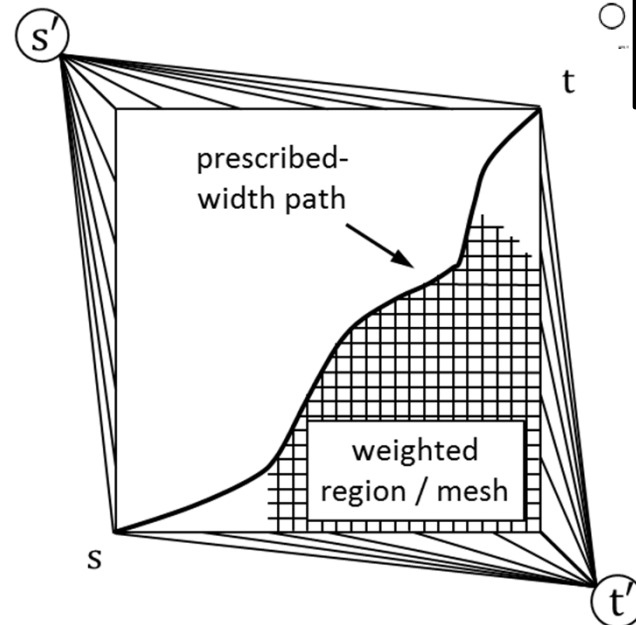
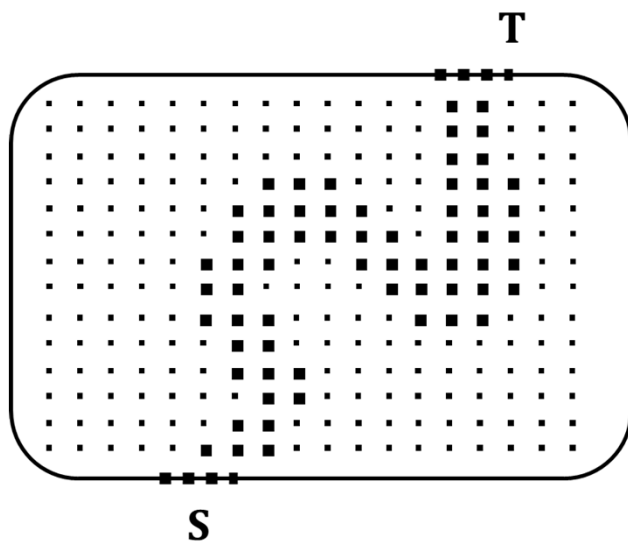

Applications Today

- Relevant to many difficult problems
 - Bus routing, bus feedthrough determination, etc.
- IC package routing
 - Per-net PI/SI requirement
 - Need traces of various width
 - Wide path finding (with multiple commodities) can be useful

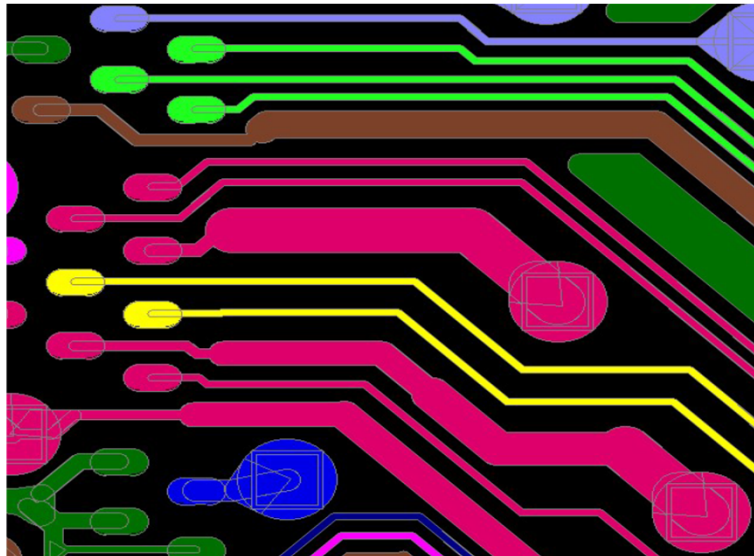

Conclusion

Professor Hu's 96 Ph.D. Descendants

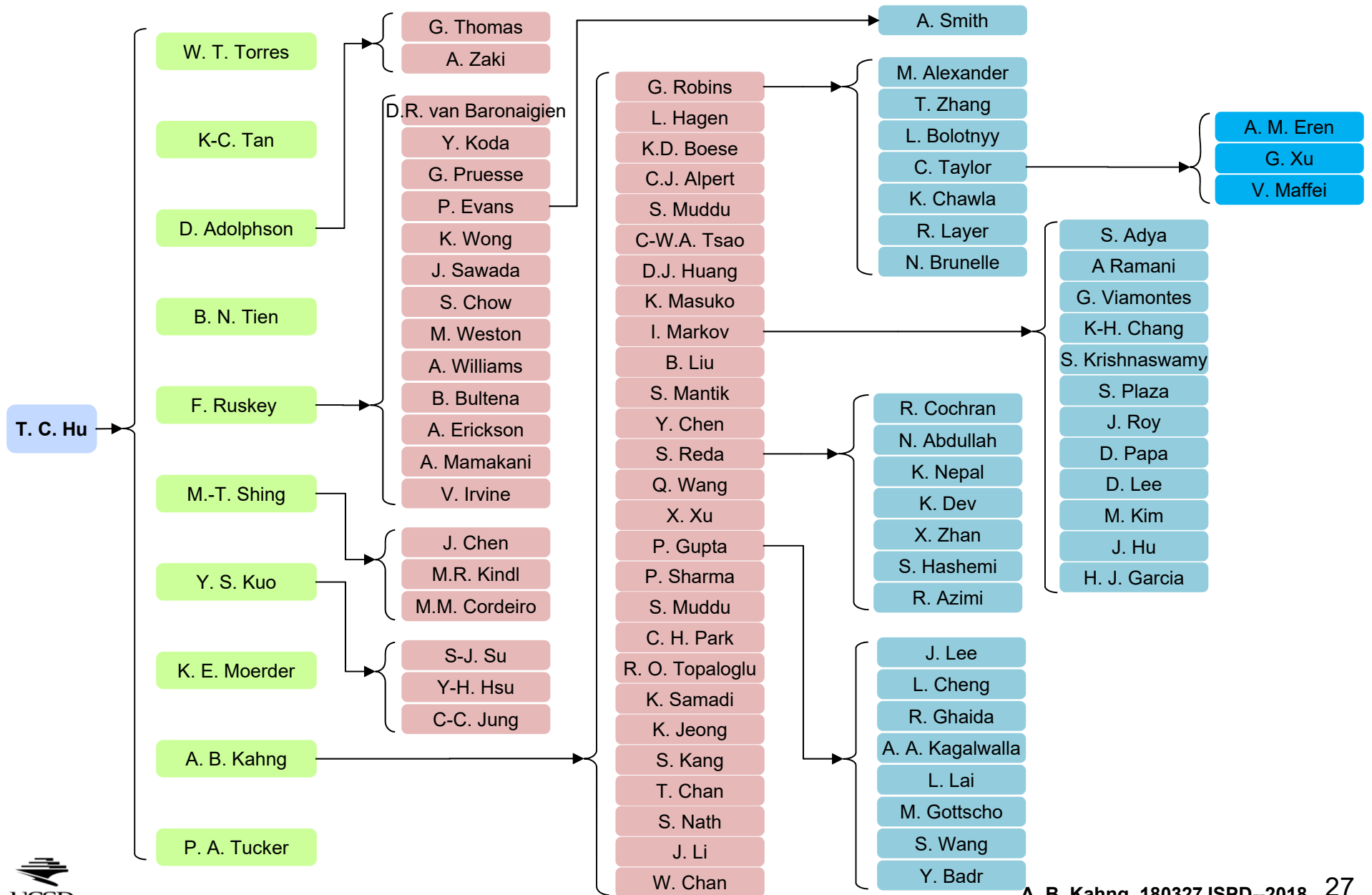

Thank you, Professor Hu.

Hypergraph Model - Useful Qualities

- Hypergraph net model
 - Sparse and symmetric
 - Enables exact representation of net cut cost
- Challenges
 - Large memory footprint for rewriting netlist - need sophisticated memory pool management and containers
 - Current systems make this feasible!
- Star net-model - separately realized in other works
 - E.g.: Defined in [Brenner01] and used in BonnPlace [Brenner08]

Minimum-cut Bipartitioning

- Show: Max-flow min-cut theorem can find a minimum-cut bipartitioning of a hypergraph
- Algorithm
 - Construct a tree - flow-equivalent to a given hypergraph
 - Similar to the Gomory-Hu cut-tree